

# GENERAL INFORMATION **PARALLEL**

## PARALLEL AND PARALLEL PROGRAMMABLE ABSOLUT ENCODERS

The absolut encoders are widely employed throughout industry. Unlike incremental measurement systems, absolut encoders always provide the true positional value. If the system is mechanically moved while power is off, when it is restored, the actual position will be immediately read.

Hohner offers a wide variety of absolut encoders, singleturn and multiturn, serial, parallel or analogue outputs, together with a wide range of output codes. It also provides the possibility of programmable encoders that allow the user to program the encoder's most important parameters.

All this enables us to offer our customers solutions to assign a specific and unique value to each shaft position.

Absolut encoders are classified into two groups: singleturn and multiturn.

Singleturn absolut encoders code the 360° of a revolution into "n" point per turn and the code is repeated for each turn.

If a measurement is required for more than one turn of the shaft, a multiturn encoder is required, which is used to provide a precise position in longer paths.

### Programmable optical absolut encoders

All essential encoder parameters are user-programmable in our programmable absolut encoders.

Available for singleturn and multiturn encoders in various mechanical options.

The programming enables the user to select the zero of reference, the number of positions per turn, up to 8192 points per turn (13 bits), the number of turns in the multiturn case, up to 4096 turns, rotation direction and output code: Binary, Gray, Excess Gra and BCD.

There are advantages, such as the possibility of electronic misadjustment and optimisation in mechanical systems that are subject to tolerances etc.

Since the same encoder can be installed in different applications and their specific programming assigned during the actual installation, this translates into savings in both stock and maintenance.

### Programming the encoder

In order to program a hohner encoder, a PC is required, together with the programming software and the connection cable between the encoder and PC (the last two are supplied with the encoder).

The encoder is connected to a power supply (24vdc) and the communications cable is connected to

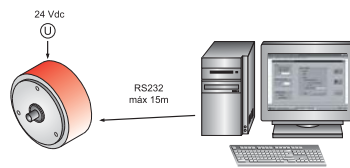

the PC serial port.

By following the simple instruction in the manual, the user will be able to program the most important encoder parameters in a simple manner.

### Output codes

In singleturn encoders, hohner can offer any resolution per turn, up to a maximum of 21 bits per turn (2.097.152 points per turn). Any number of turns 2n, can be provided up to 4096 turns, in other words 2, 4, 8, 16, 32 etc up to 4096. Codes are available in both clockwise and counter clockwise directions. In the clockwise direction, the code increases when the shaft rotates in a clockwise direction looking at the shaft. In the counter clockwise direction, the code increases when the shaft rotates in a counter clockwise direction looking at the shaft.

### Binary code

The binary code is based on 2, in other words, the information is coded using only "0" and "1".

### Gray code

The Gray code is a special form of binary code where only one bit changes from one combination to another, this permits higher transmission speeds and greater security, because in the case of natural binary codes, for example, "n" bits are changed and there is a series of intermediate steps that can be interpreted as other positions, and depending on the data read speed of the control system, one of these intermediate positions could constitute incorrect data if one bit changes faster than the others.

The Gray code is therefore, a very reliable code for data transmission because in all cases of on position to another, only one bit varies and there are no doubtful intermediate positions between one and the next.

In the resolutions that are not "2n", the Excess Gray code allows the last combination to the first to also change by only one bit. For example 360, 72 etc, this would be for an encoder with 360 positions: (512-360)/2 = Excess 76. the code would go from 76 to 435, so that position 76 to 435 would only change one bit.

### BCD code

In certain cases, the information processed by the system must be converted to decimal so that it may be more easily interpreted, this is the main reason why Binary Coded Decimal (BCD) exists. In BCD, each decimal number is directly coded in binary in order to represent the ten digits from zero to nine, which requires four bits, meaning that each decade needs four bits

Dec	Binary Code					Gray Code					BCD Code							
											2nd decade				1st decade			
	2 <sup>4</sup>	2 <sup>3</sup>	2 <sup>2</sup>	2 <sup>1</sup>	2 <sup>0</sup>	2 <sup>4</sup>	2 <sup>3</sup>	2 <sup>2</sup>	2 <sup>1</sup>	2 <sup>0</sup>	2 <sup>3</sup>	2 <sup>2</sup>	2 <sup>1</sup>	2 <sup>0</sup>	2 <sup>3</sup>	2 <sup>2</sup>	2 <sup>1</sup>	2 <sup>0</sup>
0	0	0	0	0	0	0	0	0	0	0	0	0	0	0	0	0	0	0
1	0	0	0	0	1	0	0	0	0	1	0	0	0	0	0	0	0	1
2	0	0	0	1	0	0	0	0	1	1	0	0	0	0	0	0	1	0
3	0	0	0	1	1	0	0	0	1	0	0	0	0	0	0	0	1	1
4	0	0	1	0	0	0	0	1	1	0	0	0	0	0	1	0	0	0
5	0	0	1	0	1	0	0	1	1	1	0	0	0	0	1	0	0	1
6	0	0	1	1	0	0	0	1	0	0	0	0	0	0	1	1	0	0
7	0	0	1	1	1	0	0	1	0	0	0	0	0	0	1	1	1	1
8	0	1	0	0	0	0	1	1	0	0	0	0	0	1	0	0	0	0
9	0	1	0	0	1	0	1	1	0	0	0	0	0	1	0	0	0	1
10	0	1	0	1	0	0	1	1	1	1	0	0	0	0	0	0	0	0
11	0	1	0	1	1	0	1	1	1	0	0	0	0	1	0	0	0	1
12	0	1	1	0	0	0	1	0	1	0	0	0	0	1	0	0	1	0
13	0	1	1	0	1	0	1	0	1	1	0	0	0	1	0	0	1	1
14	0	1	1	1	0	0	1	0	0	0	0	0	0	1	0	1	0	0
15	0	1	1	1	1	0	1	0	0	0	0	0	0	1	0	1	0	1
16	1	0	0	0	0	1	1	0	0	0	0	0	0	1	0	1	1	0













Correspondence table from Decimal to Binary, to Gray and to BCD.

# ABSOLUT ENCODERS **PARALLEL**

- Resolution up to 24 bits
- Solid (CS) and hollow shaft (HS)
- Protection class IP65 or IP67 according to DIN 40050
- Available any positions number per turn
- Direction, code, enable, store and reset selection
- Output codes: Binary, Gray, Gray excess or BCD
- Radial or axial connection, cable or connector output



## OVERVIEW

	Diameter 58 mm		Diameter 90 mm
	Solid shaft	Hollow shaft	Solid shaft
Singleturn	CS10 CS10 IP67 	HS10 	CS30 CS30 IP67 
Programmable singleturn	CSP10 	HSP10 	CSP30 
Multiturn	CM10 CM10 IP67 	HM10 	CM30 CM30 IP67 
Programmable multiturn	CMP10 	HMP10 	CMP30 

## TECHNICAL SPECIFICATIONS

	Diameter 58 mm	Diameter 90 mm
Housing	Aluminium/Stainless steel	
Shaft	Stainless steel	
Bearings	Ballraces	
Bearings lifetime	1x10 <sup>10</sup> rev.	
Maximum number of revolutions permitted mechanically	6000 rpm.	
Protection against dust and splashes according to DIN 40050	IP65 / IP67.	
Rotor inertia moment	30 gcm <sup>2</sup>	270 gcm <sup>2</sup>
Starting torque 20°C (68°F)	Max. 2,0 Ncm	Max. 5,0 Ncm
Maximum load permitted on axial shaft	40 N	80 N
Maximum load permitted on radial shaft	60 N	100 N
Misalignment permitted axial (blind hollow shaft)	±0.5 mm	-
Misalignment permitted radial (blind hollow shaft)	±0.3 mm	-
Weight aprox.	400 g ST, 500 g MT	1,2 kg ST, 1,3 kg MT
Operating temperature range	-10°C a +70°C	
Vibration	100 m/s <sup>2</sup> (10Hz...2000Hz)	
Shock	1000 m/s <sup>2</sup> (6ms)	
Consumption max.	100 mA (CS/HS), 150 mA (CM/HM)	
Power supply	10..30Vdc	
Interface	Parallel	
Electrical output	Push-pull, NPN, NPN Open Collector	
Configurable parameters (programmable series)	Direction, code, store, enable, reset, preset1, preset2	
Configurable parameters	Direction and reset	
Inputs	Opto-coupled	
Available codes	Binary, gray and BCD	
Max. points per turn	8192 positions (13 bits)	
Max. turns	4096 turns (12 bits)	
Linearity	±1/2 LSB	
Radial and axial connection	2 metres cable or industrial connector	

ST: Singleturn MT: Multiturn

**hohner**  
AUTOMATICOS S.L.

**SINGLETURN ABSOLUT ENCODER**

- Singleturn resolution up to 13 bits
- Protection class IP65 according to DIN 40050
- External diameter 58 mm
- Solid shaft (CS) and blind hollow shaft (HS)

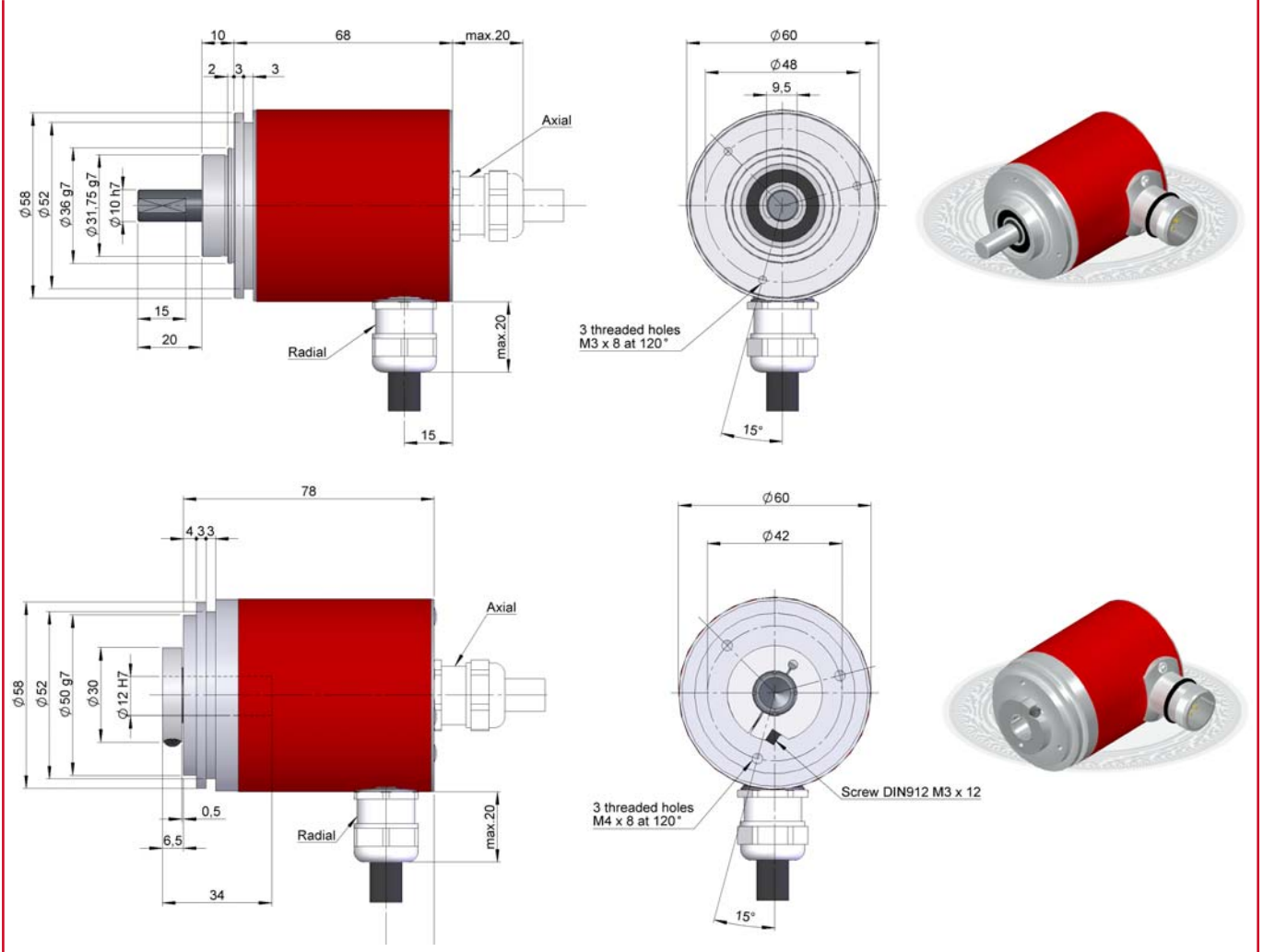

Previous mounting and installation of the encoder is recommended to read the section "TECHNICAL CONSIDERATIONS".

**ORDERING CODE**

TYPE	SERIE	SHAFT	FLANGE	CONNEX-TION	AXIAL RADIAL	INTERFACE	CODE	IP	POWER SUPPLY OUTPUT	CONFIG. PARAMETERS	RESOLUTION	SPECIAL CUSTOMER
<p>● ● 10</p> <p><b>CS-</b> Singleturn Solid shaft</p> <p><b>HS-</b> Singleturn Blind hollow shaft</p>												
		<ul style="list-style-type: none"> <li>1- Solid Ø6x10 mm</li> <li>2- Solid Ø10x20 mm</li> <li>3- Blind hollow Ø12 mm</li> <li>4- Blind hollow Ø10 mm</li> </ul>	<ul style="list-style-type: none"> <li>1- None</li> <li>2- 90.1002</li> <li>3- 90.1003</li> <li>4- 90.1004</li> <li>5- 90.1005</li> <li>6- 90.1006</li> </ul>	<ul style="list-style-type: none"> <li>1- Cable</li> <li>3- 90.9512</li> <li>4- 90.9516</li> <li>5- 90.9521</li> </ul>	<ul style="list-style-type: none"> <li>1- Axial</li> <li>2- Radial</li> </ul>	<ul style="list-style-type: none"> <li>0- Parallel</li> </ul>	<ul style="list-style-type: none"> <li>1- Binary CW</li> <li>2- Binary CCW</li> <li>3- Gray CW</li> <li>4- Gray CCW</li> <li>5- Gray excess CW</li> <li>6- Gray excess CCW</li> <li>7- BCD CW</li> <li>8- BCD CCW</li> </ul>	<ul style="list-style-type: none"> <li>1- IP65</li> </ul>	<ul style="list-style-type: none"> <li>2- 10...30 Vdc NPN</li> <li>3- 10...30 Vdc Push-Pull</li> <li>4- 10...30 Vdc NPN OC</li> </ul>	<ul style="list-style-type: none"> <li>R- Reset</li> <li>S- Direction</li> </ul>		

### MULTITURN ABSOLUT ENCODER

- Multiturn resolution up to 24 bits
- Protection class IP65 according to DIN 40050
- External diameter 58 mm
- Solid shaft (CM) and blind hollow shaft (HM)

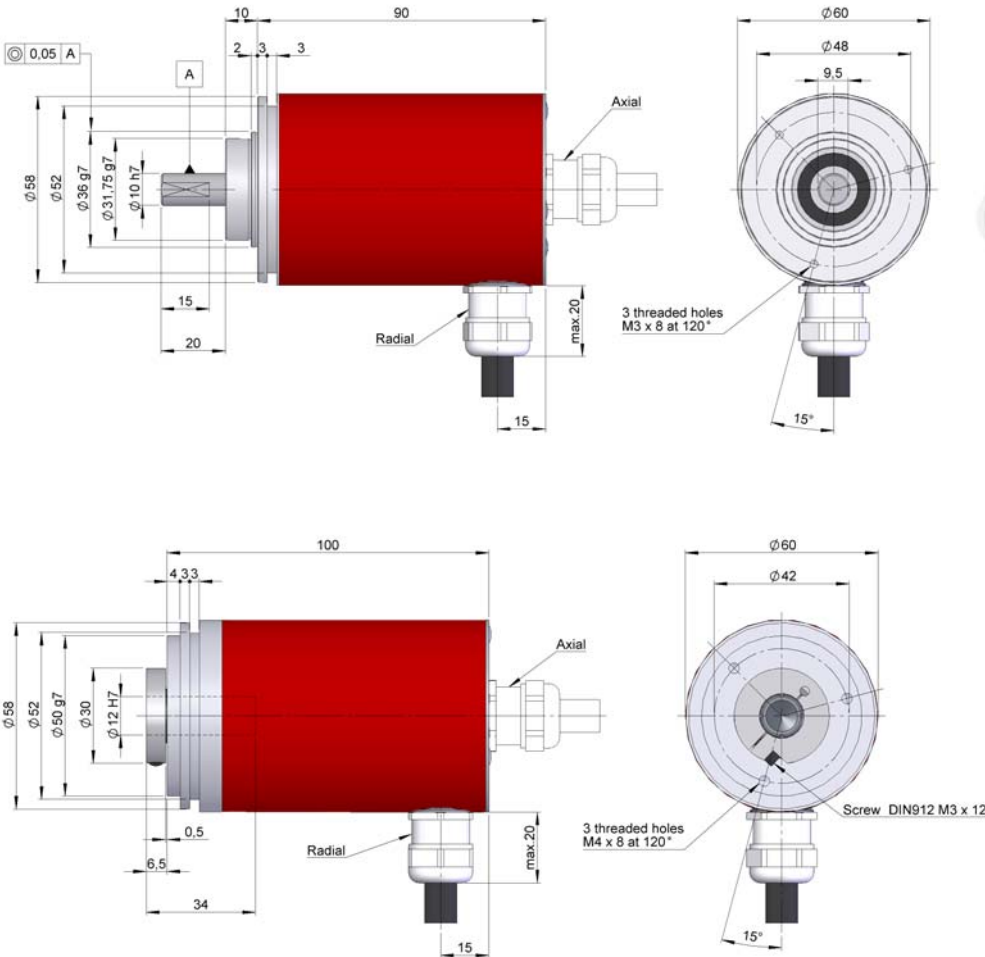

Previous mounting and installation of the encoder is recommended to read the section "TECHNICAL CONSIDERATIONS".

### ORDERING CODE

TYPE	SERIE	SHAFT	FLANGE	CONNECTION	AXIAL RADIAL	INTERFACE	CODE	IP	POWER SUPPLY OUTPUT	CONFIG. PARAMETERS	SINGLETURN RESOLUTION	MULTITURN RESOLUTION	SPECIAL CUSTOMER
● ●	10	●	●	●	●	●	●	●	●	● ● ● ● ● ● ● ● ● ●	● ● ● ● ● ● ● ●	● ●	
CM- Multiturn Solid shaft		1- Solid Ø10x20 mm 2- Solid Ø6x10 mm 3- Blind hollow Ø12 mm 4- Blind hollow Ø10 mm	1- None 2- 90.1002 3- 90.1003 4- 90.1004 5- 90.1005 6- 90.1006	1- Cable 2- 90.9512 3- 90.9516 4- 90.9512 5- 90.9516 6- 90.9526	1- Axial 2- Radial	0- Parallel	1- Binary CW 2- Binary CCW 3- Gray CW 4- Gray CCW 5- Gray excess CW 6- Gray excess CCW 7- BCD CW 8- BCD CCW	1- IP65	2- 10...30 Vdc NPN 3- 10...30 Vdc Push-Pull 4- 10...30 Vdc NPN OC	R- Reset S- Direction			





# PARALLEL PROGRAMMABLE SERIES CSP10 / HSP10

## SINGLETURN ABSOLUT ENCODERS

- Programming by PC up to 13 bits
- Protection class IP65 according to DIN 40050
- External diameter 58 mm
- Solid shaft (CSP) and blind hollow shaft (HSP)

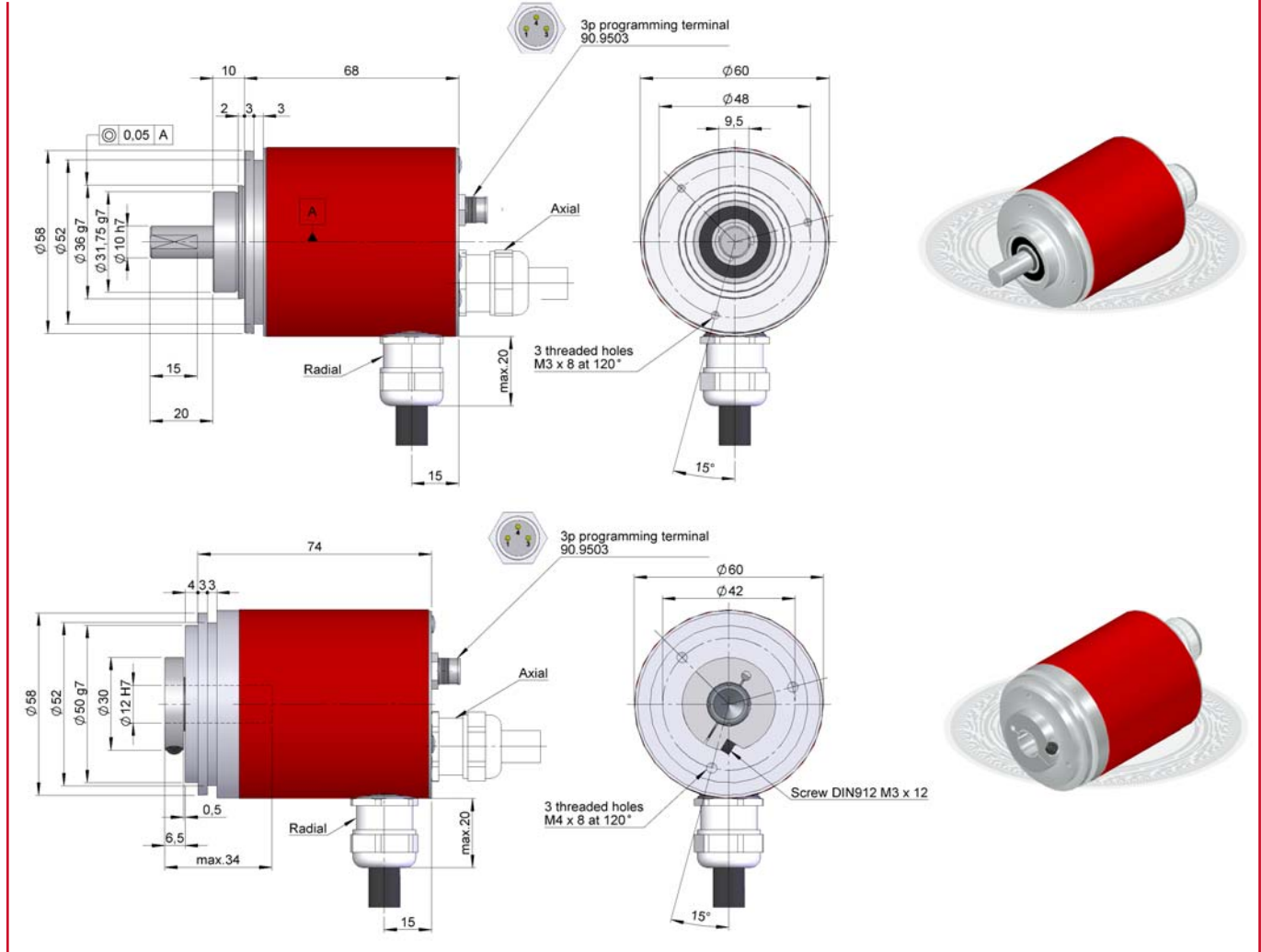

Previous mounting and installation of the encoder is recommended to read the section "TECHNICAL CONSIDERATIONS".

## ORDERING CODE

TYPE	SERIE	SHAFT	FLANGE	CONNECTION	AXIAL RADIAL	INTERFACE	CODE	IP	POWER SUPPLY OUTPUT	RESOLUTION	SPECIAL CUSTOMER
● ●	10	●	●	●	●	●	●	●	●	8192	● ●
CSP-Solid shaft HSP-Blind hollow shaft			1- None 2- 90.1002 3- 90.1003 4- 90.1004 5- 90.1005 6- 90.1006		1- Axial 2- Radial	0- Parallel		1- IP65			
							9- Prog by PC		3- 10...30 Vdc Push-Pull		
		1- Solid Ø6x10 mm 2- Solid Ø10x20 mm 3- Blind hollow Ø12 mm 4- Blind hollow Ø10 mm		1- Cable 5- 90.9521							

**MULTITURN ABSOLUT ENCODER**

- Programming by PC up to 24 bits
- Protection class IP65 according to DIN 40050
- External diameter 58 mm
- Solid shaft (CMP) and blind hollow shaft (HMP)

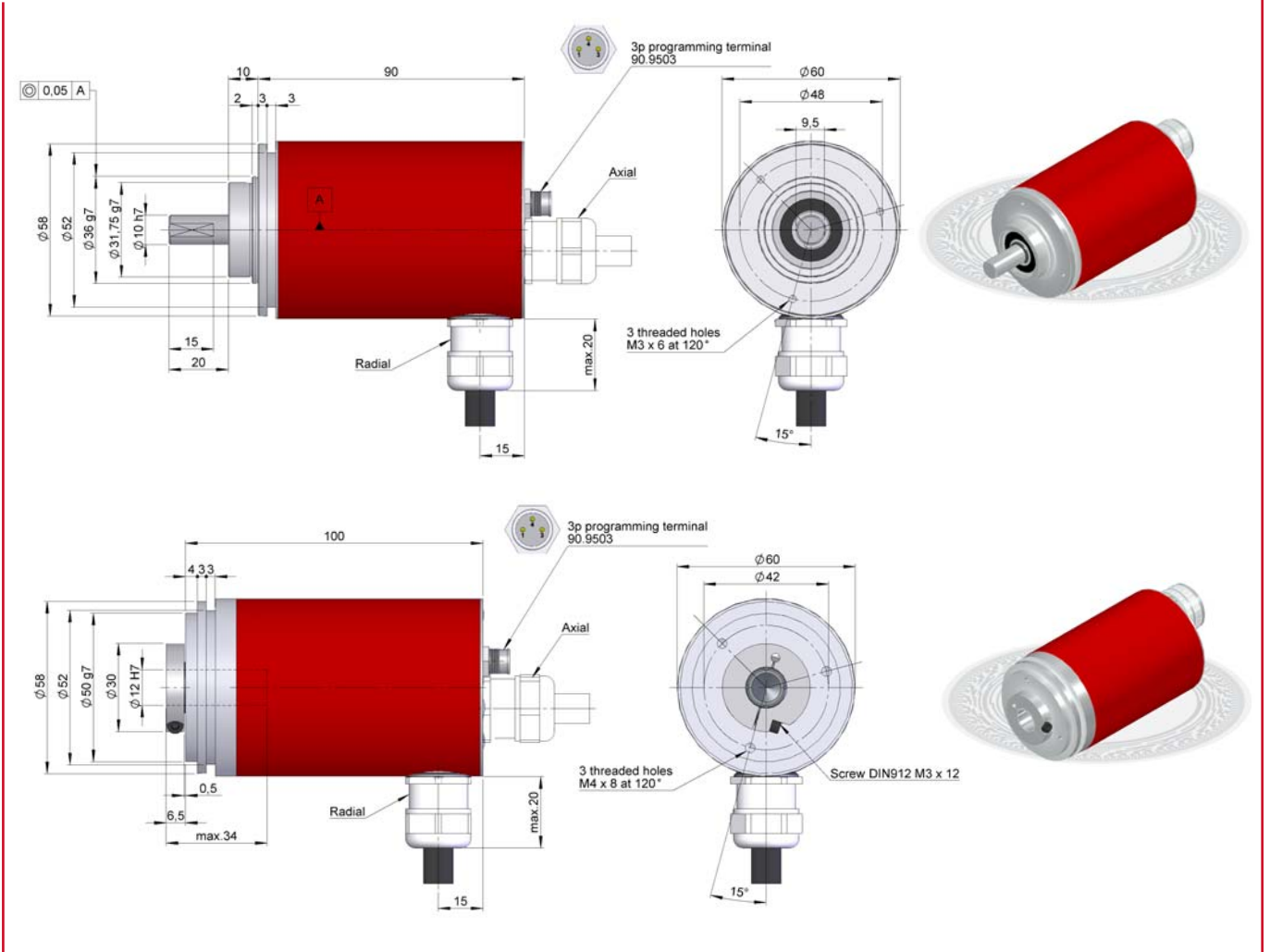

Previous mounting and installation of the encoder is recommended to read the section "TECHNICAL CONSIDERATIONS".

**ORDERING CODE**

TYPE	SERIE	SHAFT	FLANGE	CONNECTION	AXIAL RADIAL	INTERFACE	CODE	IP	POWER SUPPLY OUTPUT	SINGLETURN RESOLUTION	MULTITURN RESOLUTION	SPECIAL CUSTOMER
● ● ●	10	●	●	●	●	●	●	●	●	8192 / 2048	● ●	
<b>CMP-</b> Solid shaft <b>HMP-</b> Blind hollow shaft		1- Solid Ø10 mm 2- Solid Ø6 mm 3- Blind hollow Ø12 mm 4- Blind hollow Ø10 mm	1- None 2- 90.1002 3- 90.1003 4- 90.1004 5- 90.1005 6- 90.1006	1- Cable 6- 90.9526	1- Axial 2- Radial	0- Parallel 9- Prog by PC		1- IP65	3- 10...30 Vdc Push-Pull			

# PARALLEL PROGRAMMABLE SERIES CSP30 / CMP30

## PROGRAMMABLE ABSOLUT ENCODER FOR HEAVY DUTY INDUSTRIAL APPLICATIONS

- Programming by PC singleturn (CSP) up to 13 bits or multiturn (CMP) programming by PC up to 24 bits
- Protection class IP65 according to DIN 40050
- External diameter 90 mm
- Solid shaft

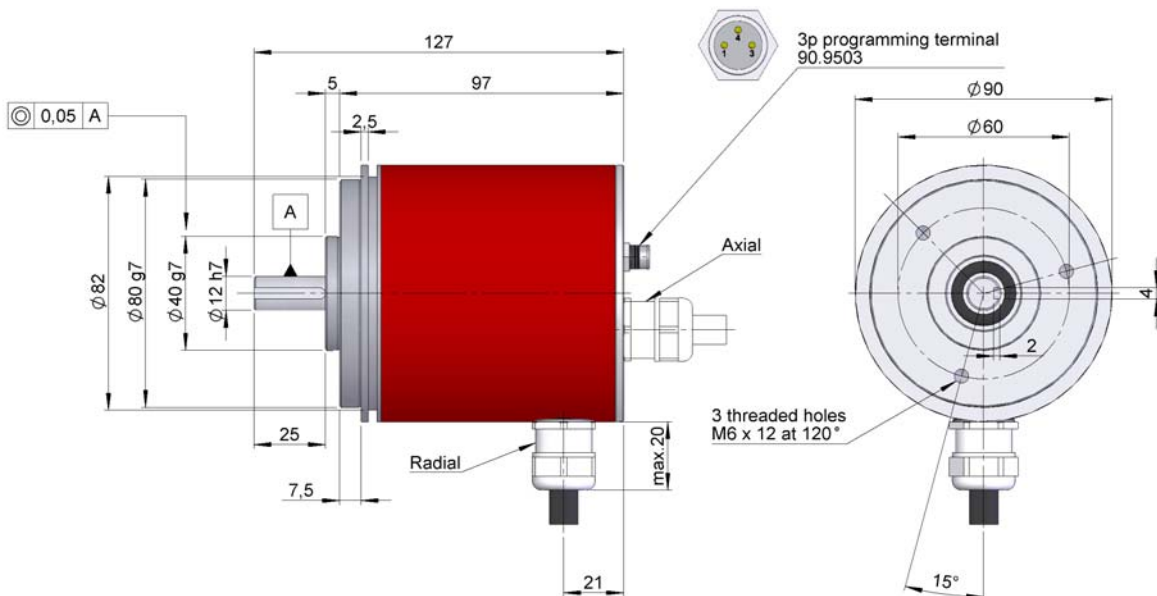

Previous mounting and installation of the encoder is recommended to read the section "TECHNICAL CONSIDERATIONS".

### ORDERING CODE

TYPE	SERIE	SHAFT	FLANGE	CONNECTION	AXIAL RADIAL	INTERFACE	CODE	IP	POWER SUPPLY OUTPUT	SINGLETURN RESOLUTION	MULTITURN RESOLUTION	SPECIAL CUSTOMER
● ● ●	30	●	●	●	●	●	●	●	●	8192 / 2048		● ●
CSP- Singleturn CMP- Multiturn		2- $\varnothing 12 \times 25$ mm	1- None 3- 90.1008	1- Cable 5- 90.9521 6- 90.9526	1- Axial 2- Radial	0- Parallel	9- Prog by PC	1- IP65	3- 10...30 Vdc Push-Pull			



## SINGLETURN ABSOLUT ENCODER FOR SEVERE APPLICATIONS

- Singleturn resolution up to 13 bits
- Protection class IP67 according to DIN 40050
- External diameter 58 mm
- Solid shaft

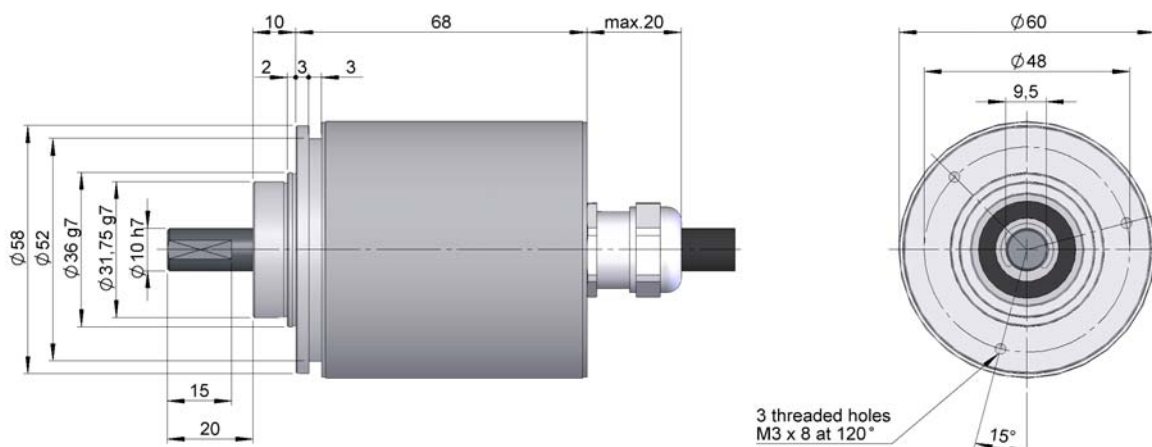
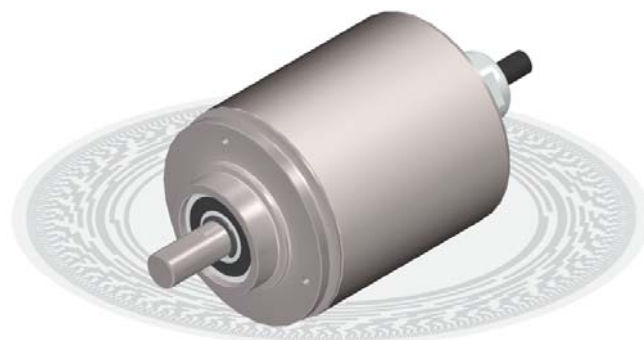

Previous mounting and installation of the encoder is recommended to read the section "TECHNICAL CONSIDERATIONS".

### ORDERING CODE

TYPE	SERIE	SHAFT	FLANGE	CONNECTION	AXIAL RADIAL	INTERFACE	CODE	IP	POWER SUPPLY OUTPUT	CONFIG. PARAMETERS	RESOLUTION	SPECIAL CUSTOMER
● ● CS- Singleturn	10	●	●	●	●	●	●	●	●	● ● ● ● ●	● ● ● ● ●	● ● ● ● ●
		1- $\varnothing 6 \times 10$ mm 2- $\varnothing 10 \times 20$ mm	1- None 2- 90.1002 3- 90.1003 4- 90.1004 5- 90.1005 6- 90.1006	1- Cable	1- Axial	0- Parallel	1- Binary CW 2- Binary CCW 3- Gray CW 4- Gray CCW 5- Gray excess CW 6- Gray excess CCW 7- BCD CW 8- BCD CCW	2- Stainless steel IP67 3- IP67	2- 10...30 Vdc NPN 3- 10...30 Vdc Push-Pull 4- 10...30 Vdc NPN OC	R- Reset S- Direction		

**MULTITURN ABSOLUT ENCODER FOR SEVERE APPLICATIONS**

- Multiturn resolution up to 24 bits
- Protection class IP67 according to DIN 40050
- External diameter 58 mm
- Solid shaft

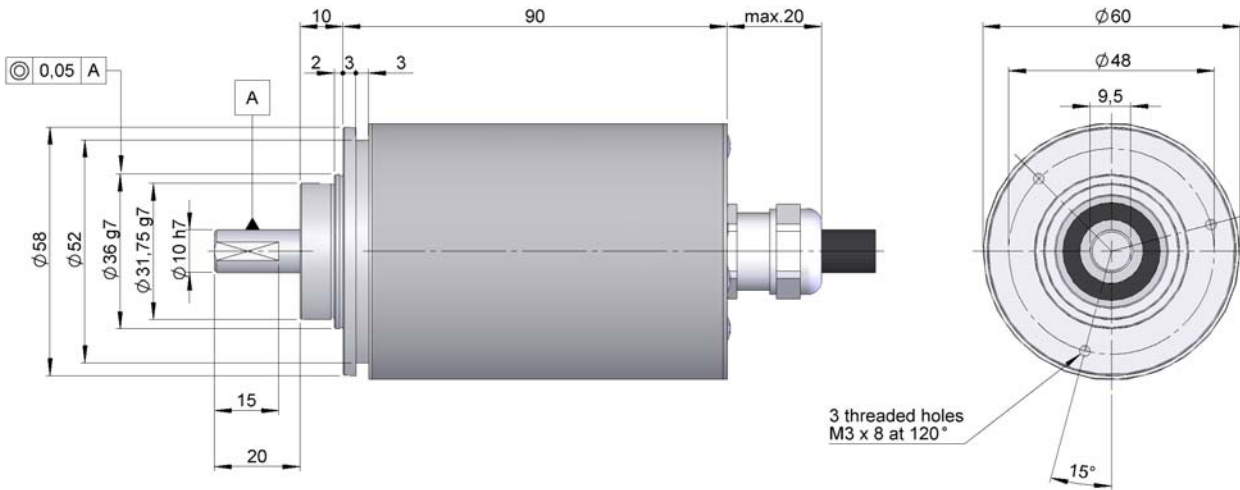

Previous mounting and installation of the encoder is recommended to read the section “TECHNICAL CONSIDERATIONS”.

**ORDERING CODE**

TYPE	SERIE	SHAFT	FLANGE	CONNECTION	AXIAL RADIAL	INTERFACE	CODE	IP	POWER SUPPLY OUTPUT	CONFIG. PARAMETERS	SINGLETURN RESOLUTION	MULTITURN RESOLUTION	SPECIAL CUSTOMER
● ● CM- Multiturn	10	●	●	●	●	●	●	●	●	● ● ● ● ● ● ● ● ● ● ● ● ● ● ● ●	● ● ● ● ● ● ● ● ● ● ● ● ● ● ● ●	● ● ● ● ● ● ● ● ● ● ● ● ● ● ● ●	● ●
		1- Ø10 x 20 mm	1- None 2- 90.1002 3- 90.1003 4- 90.1004 5- 90.1005 6- 90.1006	1- Cable	1- Axial	0- Parallel	1- Binary CW 2- Binary CCW 3- Gray CW 4- Gray CCW 5- Gray excess CW 6- Gray excess CCW 7- BCD CW 8- BCD CCW	2- Stainless steel IP67 3- IP67	2- 10...30 Vdc NPN 3- 10...30 Vdc Push-Pull 4- 10...30 Vdc NPN O.C.	R- Reset S- Direction			



# CONNECTION AND CONNECTORS

## CONNECTION CS / CSP / HS / HSP PARALLEL OUTPUT



	Cable 15 x 0.14	Cable 25 x 0.14	90.9512 M23 12p	90.9516 M23 16p	90.9521 21p	90.9526 26p
<b>GND</b>	Black	Black	1	1	1	1
<b>Vcc</b>	Red	Red	2	2	2	2
<b>Bit 0</b>	Brown	Brown	3	3	3	3
<b>Bit 1</b>	White	White	4	4	4	4
<b>Bit 2</b>	Yellow	Yellow	5	5	5	5
<b>Bit 3</b>	Green	Green	6	6	6	6
<b>Bit 4</b>	Orange	Pink	7	7	7	7
<b>Bit 5</b>	Violet	Orange	8	8	8	8
<b>Bit 6</b>	Grey	Grey	9	9	9	9
<b>Bit 7</b>	Blue	Blue	10	10	10	10
<b>Bit 8</b>	White - Black	Yellow - Black	11	11	11	11
<b>Bit 9</b>	White - Red	Yellow - Red	12	12	12	12
<b>Bit 10</b>	White - Brown	Yellow - Brown		13	13	13
<b>Bit 11</b>	White - Yellow	Yellow - Green		14	14	14
<b>Bit 12</b>	White - Blue	Yellow - Grey		15	15	15
<b>Bit 13</b>		Yellow - Blue		16	16	16
<b>Bit 14</b>		White - Black			17	17
<b>Bit 15</b>		White - Red			18	18
<b>DIR</b>	White - Yellow	White - Pink	11	15	20	25
<b>RES</b>	White - Blue	White - Blue	12	16	21	26

## CONNECTION CM / CMP / HM / HMP PARALLEL OUTPUT



	Cable 15 x 0.14	Cable 25 x 0.14	Cable 36 x 0.14	90.9512 M23 12p	90.9516 M23 16p	90.9521 21p	90.9526 26p	90.9537 SUBD 37p
<b>GND</b>	Black	Black	Black	1	1	1	1	1
<b>Vcc</b>	Red	Red	Red	2	2	2	2	2
<b>Bit 0</b>	Brown	Brown	Brown	3	3	3	3	3
<b>Bit 1</b>	White	White	White	4	4	4	4	4
<b>Bit 2</b>	Yellow	Yellow	Yellow	5	5	5	5	5
<b>Bit 3</b>	Green	Green	Green	6	6	6	6	6
<b>Bit 4</b>	Orange	Pink	Pink	7	7	7	7	7
<b>Bit 5</b>	Violet	Orange	Orange	8	8	8	8	8
<b>Bit 6</b>	Grey	Grey	Grey	9	9	9	9	9
<b>Bit 7</b>	Blue	Blue	Blue	10	10	10	10	10
<b>Bit 8</b>	White - Black	Yellow - Black	Yellow - Black	11	11	11	11	11
<b>Bit 9</b>	White - Red	Yellow - Red	Yellow - Red	12	12	12	12	12
<b>Bit 10</b>	White - Brown	Yellow - Brown	Yellow - Brown		13	13	13	13
<b>Bit 11</b>	White - Yellow	Yellow - Green	Yellow - Green		14	14	14	14
<b>Bit 12</b>	White - Blue	Yellow - Grey	Yellow - Pink		15	15	15	15
<b>Bit 13</b>		Yellow - Azul	Yellow - Grey		16	16	16	16
<b>Bit 14</b>		White - Black	Yellow - Blue			17	17	17
<b>Bit 15</b>		White - Red	White - Black			18	18	18
<b>Bit 16</b>		White - Brown	White - Red			19	19	19
<b>Bit 17</b>		White - Green	White - Brown			20	20	20
<b>Bit 18</b>		White - Pink	White - Green			21	21	21
<b>Bit 19</b>		White - Orange	White - Pink				22	22
<b>Bit 20</b>		White - Grey	White - Orange				23	23
<b>Bit 21</b>		White - Blue	White - Grey				24	24
<b>Bit 22</b>			White - Blue				25	25
<b>Bit 23</b>			Green - Black				26	26
<b>DIR</b>	White - Yellow	Yellow - Pink	Grey - Brown	11	15	20	25	36
<b>RES</b>	White - Blue	White - Blue	Grey - Blue	12	16	21	26	37